



CYNGOR GWYNEDD COUNCIL

TRWYDDED ADRAN 184 - SECTION 184 Licence

Deddf Priffyrdd 1980 - Highways Act 1980

Cyngor Gwynedd

Caernarfon

Gwynedd

LL55 1SH

CAIS AM DRWYDDED YN YMWNEUD Â :

Adran 184 - Adeiladu/newid mynedfa i gerbydau dros Briffordd Gyhoeddus

*Deddf Ffyrdd Newydd a Gwaith Stryd 1991
Deddf Priffurdd 1980*



APPLICATION FOR LICENCE RELATING TO :

Section 184 – Construct/alter vehicular access over the Public Highway

*New Roads and Street Works Act 1991
Highways Act 1980*

<p>Rhaid cyflwyno'r canlynol gyda'r cais :</p> <ul style="list-style-type: none"> • Copi map o'r lleoliad/cynllun gwaith i raddfa • Cynllun Rheoli Traffig (lle bo angen) • Cais Cau Ffordd (lle bo angen) • Copiau o caridiau llun Gwaith Stryd goruchwylwr a gweithredydd(ion) achrededig • Copi o Yswiriant Atebolrwydd Cyhoeddus y contractwr (os nad ydym wedi ei dderbyn yn flaenorol) • Ffi na ellir ei ad-dalu 	<p><i>The following must be submitted with the application :</i></p> <ul style="list-style-type: none"> • <i>A copy of the location map/plan of works to scale</i> • <i>Traffic Management Plan (where necessary)</i> • <i>Road Closure Application (where necessary)</i> • <i>Copies of Street Works photo cards of accredited supervisor and operative(s)</i> • <i>A copy of the contractors Public Liability Insurance (if we have not previously received it)</i> • <i>Non-refundable fee</i>
--	---

Math o Cais / Type of Application

Adeiladu/newid mynediad i gerbydau dros y briffordd gyhoeddus	Construct/alter vehicular access over a public highway
---	--

Lleoliad Gwaith Arfaethedig / Location of Proposed Works

Cyfeiriad Llawn (gan cynnwys Cod Post)		Full Address (including Post Code)
Rhif Cyfeirnod Stryd Unigryw (RhCSU)		Unique Street Reference Number (USRN)
Cyfeirnod Grid Arolwg Ordnans (CGAO) neu Cyfesurynnau (Dwyreiniadau a Gogleddiadau)		Ordnance Survey Grid Reference (OSGR) or Co-ordinates (Eastings and Northings)
Disgrifiad byr o'r gwaith		Brief description of works
Dyddiad o		Date from
Cyfnod y gwaith		Duration of works

Manylion Ymgeisydd / Applicant Details

Enw Llawn		Full Name
Cyfeiriad e-bost		E-mail address
Cyfeiriad Llawn (gan gynnwys Cod Post)		Full Address (including Post Code)
Rhif ffon		Telephone number

Manylion Contractwr / Contractor Details

Enw Llawn		Full Name
Ar ran (Sefydliad)		On behalf of (Company)
Cyfeiriad e-bost		E-mail address
Cyfeiriad Llawn (gan gynnwys Cod Post)		Full Address (including Post Code)
Rhif Ffôn		Telephone Number
Rhif Ffôn Symudol		Mobile Number

Manylion Asiant (Ile bo'n berthnasol) / Agent Details (where relevant)

Enw Llawn		Full Name
Ar ran (Sefydliad)		On behalf of (Organisation)
Cyfeiriad e-bost		E-mail address
Cyfeiriad Llawn (gan gynnwys Cod Post)		Full Address (including Post Code)
Rhif Ffôn		Telephone Number
Rhif Ffôn Symudol		Mobile Number

Caniatâd Cynllunio / Planning Permission

Caniatâd Cynllunio Angenrheidiol	Oes	Yes	Planning Permission Required
	Nag Oes	No	
Dogfennau ategol gan y Awdurdod Cynllunio Lleol yn amgaaedig	Ydi	Yes	Supporting documents from Local Planning Authority attached

Datganiad / Declaration

Wrth rhoi tic yn y blwch cadarnhaf fy mod wedi darllen a deall y termau ac amodau, gwybodaeth a arweiniad, a unrhyw amodau ychwanegol gosodwyd gan yr Awdurdod. Rwyf hefyd yn deall fy nghyfrifoldeb o dan y Deddf Gwaith Ffyrdd a Strydoedd Newydd 1991, Deddf Priffyrdd 1980, a'r ddeddfwriaeth ganiatáu a Chodau Ymarfer, ac unrhyw is-ddeddfwriaeth gysylltiedig arall a Chodau Ymarfer.

By placing a tick in the box I confirm that I have read and understood the terms and conditions, information and guidance, and any further conditions imposed by the Authority. I also understand my responsibility under the New Roads and Street Works Act 1991, Highways Act 1980, and any other associated Secondary Legislation and Codes of Practice.

Amodau Safonol / Standard Conditions

1. Ffi na ellir ei ad-dalu

(i) £261.00

Dull Talu :

- Trwy ffonio (01766) 771000 (Galw Gwynedd) rhwng 9:00yb a 5:00yh a gwneud taliad gyda Cherdyn Debyd neu Gredyd. A dyfynnu'r cyfeirnod: 0600C - a.184 (YCHWANEGWCH LLEOLIAD)..

1. Non-refundable Fee

(i) £261.00

Payment Method :

By telephoning (01766) 771000 (Galw Gwynedd) between 9:00am and 5:00pm and making payment with a Debit or Credit Card. And quoting reference : 0600C - s.184 (INSERT LOCATION).

2. Bu rhaid i'r ymgeisydd:

- Gyrru'r drwydded atom oleiaf 15 diwrnod gwaith cyn dyddiad cychwynnol angenrheidiol y drwydded.
- Talu'r ffi uchod cyn bod ystyriaeth yn cael ei rhoi i'r cais.
- Dim i dechrau'r gwaith nes bod y drwydded wedi ei dderbyn.
- Trefnu bod y gwaith yn cael ei gynnal gan goruchwyliwyr a gweithredwyr sy'n achrededig oddi tan y New Roads and Street Works Act.

2. The applicant must :

- Send your request to us at least 15 working days before the required commencement date of the licence.
- Pay the above fee before consideration is given to the application.
- Not commence the works until you have received the licence.
- Arrange for work to be carried out by a New Roads and Street Works Act accredited supervisor and operative(s).

3. Bydd yr trwyddedai yn indemnio Cyngor Gwynedd yn erbyn unrhyw atafaeliadau, gweithredoedd, achosion, hawliadau, gorchmynion, cost, iawndal a threuliau y gellir eu codi neu ei wneud yn ei erbyn oherwydd unrhyw fater a allai godi yn uniongyrchol neu'n anuniongyrchol o ganlyniad i'r caniatâd hwn. Dylia'r Indemniad Atebolrwydd Cyhoesddus fod dim llai na £10 miliwn ar gyfer unrhyw un digwyddiad. Rhaid anfon copi o'r sgediwl cyn y gellir cyhoeddi'r drwydded.

3. The licensee will indemnify Cyngor Gwynedd against any distresses, actions, proceedings, claims, demands, costs, damages and expenses that may be levied, brought or made against it by reason of any matter which may rise directly or indirectly as a result of this permission. Public liability Limit of Indemnity provided should be no less than £10 million in respect of any one incident. A copy of the insurance schedule must be produced before a licence can be issued.

4. Bydd yr trwyddedai yn atebol am unrhyw ddifrod i strwythur y briffordd ac/neu i gyfarpar yr Ymgwymerwr Statudol o ganlyniad o'r gweithiau ar y briffordd a mi fydd costau gwirioneddol o atgyweirio unrhyw ddifrod yn cael ei godi gan Cyngor Gwynedd neu ei Asiantau.

4. The licensee will be held liable for any damage to the highway structure and/or Statutory Undertakers apparatus resulting from works on the highway and the actual costs of making good any damage will be charged by Cyngor Gwynedd or its Agents.

5. Mae y trwyddedai yn gyfrifol am waredu'r holl ddeunydd gwastraff o'r safle gwaith yn ddiogel.

5. The licensee is responsible for the safe removal and disposal of all waste material from the site. The applicant shall produce a list of sites where he intends to deposit waste material and copies of transfer tickets if required to do so at any time by the Highway.

6. Ni fydd caniatáu symudiad o fwd a /neu deunydd arall i'r ffordd/troedffordd. Gall methu a chydymffurfio ag unrhyw hysbysiad dilynol a gyflwynir gan yr Awdurdod Priffyrdd arwain at wneud y gwaith adfer anghenrheidiol a'r costau a godir i'r ymgeisydd.

6. Mud and/or other material should not be allowed to spread from site onto the road/footway but any contamination must be cleared immediately. Failure to comply with any subsequent notice served by the Highway Authority may result in it carrying out necessary remedial works and the costs incurred charged to the applicant.

7. Wrth weithio ar y briffordd rhaid i'r safle gael ei gadw'n gywir yn unol â Phennod 8 y Rheoliadau Arwyddion Traffig a'r Cod Ymarfer ar gyfer Diogelwch yn y Gweithfeydd Stryd. Rhaid gwneud darpariaeth ar gyfer symud traffig nad yw'n gerbyd yn ddiogel trwy gydol y gwaith.

7. When working on the highway the site must be properly signed and guarded in accordance with Chapter 8 of the Traffic Signs Regulations and the Code of Practice for Safety at Street works. Provision must be made for the safe passage of non-vehicular traffic throughout the works.

<p>8. Cyfrifoldeb yr ymgeisydd ydyw (os ydynt yn credu bod angen) i drefnu i gael marcwyr diogelu mynediad ar eu traul eu hunain. Cyfeiriwch at y dyrluniad manwl wedi'i gynnwys yn y pecyn.</p>	<p>8. It is the applicants' responsibility (if they deem necessary) to arrange for access protection markers to be put in place at their own expense and by an approved contractor. Please refer to Standard detail drawing included in the pack.</p>
<p>9. Os bod y trwyddedai yn methu a chydymffurfio ac unrhyw un o'r amodau yna mae siawns y bydd yr Awdurdod Priffyrdd yn cwblhau unrhyw waith rhagorol ac adferu'n rhesymol y costau o wneud hyn.</p>	<p>9. If the applicant fails to comply with any of the conditions then the Highway Authority may complete any outstanding works and recover the expenses reasonably incurred by them in so doing.</p>
<p>10. Noder bydd methu a chydymffurfio ag unrhyw un o'r amodau cyffredinol neu safle-penodol yn golygu fod y drwydded yn annilys.</p>	<p>10. Please note that failure to comply with any of the general or site-specific conditions will render the licence invalid.</p>

Ddylai'r ffurflen gyflawn a'r dogfennau angenrheidiol unai cael eu hanfon yn electroneg at
/ The completed form and necessary documents should either be sent electronically to:
gwaithstryd@gwynedd.llyw.cymru / streetworks@gwynedd.llyw.cymru

neu / or

trwy'r post i'r cyfeiriad uchod / by post to the address above.

**Rhestr o Contractwyr gyda chymhwyster penodedig fel Arolygwr dan y Deddf Ffyrdd
Newydd a Gwaith Stryd
List of Contractors with the prescribed New Roads and Street Works Act Qualification
as Supervisor**

Enw a Chyfeiriad/Name and Address	Rhif Ffôn/Tel. No.
A55 Construction and Civil Engineering 4 Tan Bryn Cottages LLandegai Bangor LL57 4LG	07771 636551
AE & AT Lewis LTD Rhoslan Yard LLangwyllog LLangefni Ynys Mon LL77 7PX	01248 723872
Colin Jones (Rock Engineering) Ltd., Unit 11, Penamser Industrial Estate, Porthmadog, Gwynedd. LL49 9NZ	01766 513332
Chris Owens Homes & Construction Talgwynedd Dwyran Anglesey LL61 6LQ	07970 980928
Cybi Cyf Llwyn Gwyn Llangybi Pwllheli Gwynedd. LL53 6SR	01766 819159
Derwen Llyn Construction Ltd 43 High Street Pwllheli Gwynedd, LL53 5RT	07833463474 07919251800

<p>D & C Jones Co Ltd Llwyn Gell Industrial Estate Blaenau Ffestiniog Gwynedd LL41</p>	<p>01766 830324 07531 392461</p>
<p>D.J. Mullane, Cae Gwyn, Nant Peris, Caernarfon, Gwynedd. LL55 4UH</p>	<p>01286 870718 07903 140988</p>
<p>Dragon Civil Engineering Ltd., 14 Dolwar Estate, Y Ffor, Pwllheli, Gwynedd. LL53 6UQ</p>	<p>07799588800</p>
<p>Emrys Roberts, Wnion Contractors, Penarddwnion Fach, Rhydymain, DOLGELLAU, Gwynedd. LL40 2BY</p>	<p>01341 450275</p>
<p>Eric & Rob Humphreys, 77 Bangor Street, Y Felinheli, Gwynedd.</p>	<p>01286670804 07798 664492</p>
<p>Peirianeg sifil Gelli Cyf Market Hall Tremadog LL49 9RD</p>	<p>017667514731</p>
<p>G H James, Unedau 1-3, Adeilad Utica, TRAWSFYNYDD, Gwynedd. LL41 4DU</p>	<p>01766 540 414</p>

Gwynedd Civil Engineering, Cibyn Industrial Estate, Llanberis Road, Caernarfon, Gwynedd. LL55 2BF	01766 771 000
GT Williams Ltd Pwll Parc Depot Edern Pwllheli Gwynedd LL53 8YT	01758 720391
Hogan Construction Ltd., Hogan House, Caernarfon Road, Bangor, Gwynedd. LL57 4DA	01248 353595
H J Mullane Groundworks & Fencing Bwthyn Carreg Y Fran Cwm Y Glo Caernarfon LL55 4DD	07770857454
John L. Thomas 3 Cambrian Road Tywyn Gwynedd LL36 0AG	01654 711 438
K W Jones 7 Garreg Frech Llanfrothen Penrhyndeudraeth Gwynedd LL48 6BZ	01766 771241 07774 648105
M G Williams & Son 21 Bro Wyled Rhostryfan Caernarfon Gwynedd LL54 7LP	01286 830104 07900591254
O Jones Penbrynhuddig Abererch Pwllheli Gwynedd	01758 613328 01758 614467

Peter burgess & Son Derlwyn Ffordd Bangor Bethesda Gwynedd LL57 3EU	01248 601 227 07775 506052
R G Hire Ltd Bryn y Gwynt Caergeiliog Ynys Mon LL65 3EX	01407 741151 07967 027492

S. J. & S. Williams Limited Hendre Edern Pwllheli Gwynedd LL53 8YS	01758 720973
Tom James Construction Services 5 Benar View Blaenau Ffestiniog Gwynedd LL41 3UT	01766 831560
William Hughes (Peirianyddiaeth Sifil) Cyf Swyddfeydd W.H. Bodffordd Llangefni Ynys Mon LL57 7DZ	01248 750193 01248 750079

RHAN N
HYSBYSIAD GWAITH
(YN CYNNWYS YMATEB)

Deddf Strydoedd Newydd a Gwaith Stryd 1991



PART N
NOTICE OF WORKS
(INCLUDING RESPONSES)

New Roads and Street Works Act 1991

Cyfeirnod Gwaith	Work Reference
------------------	----------------

Manylion Ymgeisydd / Applicant Details

Enw Llawn		Full Name
Ar ran (Sefydliad)		On behalf of (Organisation)
Cyfeiriad e-bost		E-mail address
Cyfeiriad Llawn (gan gynnwys Cod Post)		Full Address (including Post Code)
Rhif Ffôn Rhif Ffôn Symudol		Telephone Number Mobile Number
Manylion Cyswllt Mewn Argyfwng : Enw Rhif Ffôn		Emergency Contact Details : Name Telephone Number

Math o Rybudd (ticiwch fel yn briodol) / Type of Notice (tick as appropriate)

Rhybudd Gwreiddiol	<i>Initial Notice</i>	Rhybudd Cadarnhad	<i>Confirmation Notice</i>
Ymateb Awdurdod Stryd	<i>Street Authority Response</i>	Canslo	<i>Cancellation</i>
Rhybudd Cychwyn	<i>Start Notice</i>	Rhybudd Stopio	<i>Stop Notice</i>
Parhad Diwygiedig	<i>Revised duration</i>	Arall	<i>Other</i>

Dyddiad cyflwyno		Date of issue
Amser cyflwyno (Argyfwng a Brys yn unig)		Time of issue (Emergency & Urgent only)
Dyddiad disgwylir dechrau		Expected start date
Dyddiad disgwylir cwblhau		Expected completion date

Categori Gwaith (ticiwch fel yn briodol) / Works Category (tick as appropriate)

Mân (gweithiau yn para hyd at 3 diwrnod) angen 3 diwrnod o rybudd	<i>Minor (works lasting up to 3 days)</i> 3 days notice required
Safonol (gweithiau yn para rhwng 4 a 10 diwrnod) angen 10 diwrnod o rybudd	<i>Standard (works lasting between 4 and 10 days)</i> 10 days notice required
Mawr (gweithiau yn para fwy na 10 diwrnod) angen 3 mis o rybudd cychwynnol ac yna rhybudd cychwyn safonol o 10 diwrnod	<i>Major (works lasting more than 10 days)</i> 3 months notice required followed by a standard 10 days start notice
Argyfwng / Brys (angen rhybudd 2 awr wedyn)	Emergency / Urgent (notice required 2 hours after)

Gwaith Adfer (ticiwch fel yn briodol) / Remedial Reinstatement (tick as appropriate)		
Perygl (2 awr wedyn)		<i>Dangerous (2 hours after)</i>
Arall (3 diwrnod)		<i>Other (3 days)</i>
Manylion Lleoliad / Proposed Location of Works		
Enw / Rhif Tŷ		<i>House Name / Number</i>
Enw Stryd		<i>Street Name</i>
Pentref / Tref		<i>Village / Town</i>
Côd Post		<i>Post Code</i>
Rhif Cyfeirnod Stryd Unigryw (RhCSU)		<i>Unique Street Reference Number (USRN)</i>
Cyfeirnod Grid Arolwg Ordnans (CGAO) neu Cyfesurynnau (Dwyreiniadau a Gogleddiadau)		<i>Ordnance Survey Grid Reference (OSGR) Or Co-ordinates (Eastings and Northings)</i>
Disgrifiad byr o'r gwaith ac unrhyw sylwadau (e.e. Rheolaeth traffig neu drafferthion peirianneg arbennig)		<i>Brief description of works and any comments (e.g. traffic management or special engineering difficulties)</i>
Nodyn / Note		
Nid yw Cyngor Gwynedd yn derbyn unrhyw atebolrwydd am anghyfleustra, cost neu golled a achoswyd o ganlyniad i'r ceisiadau gael eu prosesu'n hwyr oherwydd diffyg gwybodaeth a chyflwynwyd gan yr ymgeisydd.		<i>Cyngor Gwynedd does not accept liability for any inconvenience, loss or costs incurred as a result of the applications being processed late due to lack of information submitted by the applicant.</i>

Ddylai'r ffurflen gyflawn cael eu hanfon yn at / *The completed form should be sent to :*
gwaithstryd@gwynedd.llyw.cymru / streetworks@gwynedd.llyw.cymru

neu / or

trwy'r post i'r cyfeiriad isod / *by post to the address below :*

Cyngor Gwynedd
 Adran Amgylchedd / *Environment Department*
 Gwasanaeth Trafnidiaeth a Chefn Gwlad / *Transport and Countryside Service*
 Stryd y Jêl / *Shirehall Street*
 Caernarfon
 Gwynedd
 LL55 1SH

RHAN R1
COFRESTRU GWAITH

Deddf Strydoedd Newydd a Gwaith Stryd 1991



PART R1
REGISTRATION OF WORKS

New Roads and Street Works Act 1991

Cyfeirnod Gwaith		Work Reference
Manylion Ymgeisydd / Applicant Details		
Enw Llawn		Full Name
Ar ran (Sefydliad)		On behalf of (Organisation)
Cyfeiriad e-bost		E-mail address
Cyfeiriad Llawn (gan gynnwys Cod Post)		Full Address (including Post Code)
Rhif Ffôn		Telephone Number
Rhif Ffôn Symudol		Mobile Number
Manylion Cyswllt Mewn Argyfwng : Enw Rhif Ffôn		Emergency Contact Details : Name Telephone Number

Lleoliad y Gwaith Arfaethedig / Poposed Location of Works		
Enw / Rhif Tŷ		House Name / Number
Enw Stryd		Street Name
Pentref / Tref		Village / Town
Côd Post		Post Code
Rhif Cyfeirnod Stryd Unigryw (RhCSU)		Unique Street Reference Number (USRN)
Cyfeirnod Grid Arolwg Ordnans (CGAO) neu Cyfesurynnau (Dwyreiniadau a Gogleddiadau)		Ordnance Survey Grid Reference (OSGR) Or Co-ordinates (Eastings and Northings)

Gwybodaeth Pellach (cylchwych fel yn briodol) / Further Information (circle as appropriate)		
Ydi ffurflen Rhan N wedi ei gwblhau?	Y / N	Has Part N form been completed?
Holl waith ar yr hysbysiad yma wedi eu cwblhau? Os ydy, gwir unedau achwiliad :	Y / N	All works on this notice complete? If yes, Actual Inspection Units:

Rhif Cyfeirnod Derbynnnydd		<i>Recipient Reference Number</i>
Rhif Cyfeirnod Dechreuwr		<i>Originator Reference Number</i>
Disgrifiad byr o'r gwaith		<i>Brief description of works</i>

Manylion Adfer / Reinstatement Details (Ff = Ffordd, T = Troedffordd, Y = Ymyl / C = Carriageway, F = Footway, V = Verge)						Dyddiad Cychwyn Gwarant / Guarantee Start Date (dd-mm-bb / dd-mm-yy)						
Eitem / Item	Lleoliad / Location	Hyd / Length	Lled / Width	Ff/T/Y - C/F/V	Dyfnder Cloddio / Depth of Excavation	Cyfamser / Interim			Parhaol / Permanent			
1.												
2.												
3.												
4.												
5.												
6.												
7.												

NODYN / NOTE	
Nid yw Cyngor Gwynedd yn derbyn unrhyw atebolrwydd am anghyfleustra, cost neu golled â achoswyd o ganlyniad i'r ceisiadau gael eu prosesu'n hwyr oherwydd diffyg Gwybodaeth a chyflwynwyd gan yr ymgeisydd.	Cyngor Gwynedd does not accept liability for any inconvenience, loss or costs incurred as a result of the applications being processed late due to lack of information submitted by the applicant.

Ddylai'r ffurflen gyflawn a'r dogfennau angenrheidiol un ai cael eu hanfon yn electroneg at
/ The completed form should be sent to :

gwaithstryd@gwynedd.llyw.cymru / streetworks@gwynedd.llyw.cymru

neu / or

trwy'r post i'r cyfeiriad isod / by post to the address below :

Cyngor Gwynedd
Adran Amgylchedd / Environment Department
Gwasanaeth Trafnidiaeth a Chefn Gwlad / Transport and Countryside Service
Stryd y Jêl / Shirehall Street
Caernarfon
Gwynedd
LL55 1SH

CONSTRUCT/ALTER VEHICULAR ACCESS OVER THE PUBLIC HIGHWAY (DROPPED KERB)

Information, Guidance, and Conditions for Applicants

Introduction

A vehicular crossing, often referred to as a dropped kerb, is where the kerbs are lowered from their normal height and the pavement or verge is reconstructed to strengthen it to take the weight of the vehicle driving across it in order to give access into a property. Anyone wishing to construct/alter a vehicular access must apply for permission from Cyngor Gwynedd where a street works licence is granted under Section 184 of the Highways Act 1980. It is the function of the Council as the Highway Authority to monitor licensees' operations under the Act and ensure that the rights of the highway user are protected.

The purpose of this document is to give some guidance and information and provides the conditions that an applicant must adhere to.

General Information

A company or contractor may apply on behalf of the land or property owner, but the licence will remain in the possession of the land or property owner. The person granted a licence under Section 184 of the Act (the Licensee) must also comply with the relevant duties and responsibilities imposed by New Roads and Streetworks Act 1991, the Traffic Management Act 2004 and the associated Secondary Legislation and Codes of Practice. Those applicants not familiar with the requirements of this legislation are strongly advised to appoint a contractor with the appropriate knowledge and accreditation to help complete the application and conduct the works on their behalf.

The legal responsibility to comply with New Roads and Street Works Act 1991 belongs to the Licensee and non-compliance can lead to significant financial penalties or prosecution. A Licensee may employ a sub-contractor but the liability cannot be delegated to any other person or organisation.

Applying for the licence

You would need to consider the following points before applying for a Section 184 licence.

- If you are the tenant of a housing association or other leasehold property, you should seek the consent/agreement of your property owner.
- If you are the owner of a previously owned local authority property you must consult with the relevant housing authority e.g Cartrefi Cymunedol Gwynedd
- There must be sufficient space on your property to park a vehicle without it overhanging the public highway. This would normally be 6m in depth from the building to the front boundary of the property by 3.6m in width allowing sufficient space for gates and to walk around the vehicle. Parallel parking adjacent to the footway or verge will not be considered.
- It is advisable that you create the area within your property to park the car prior to constructing your dropped kerb. Please also see the section on planning permission.
- Any gates fitted must open inward.
- If there is any street furniture, such as a road sign/street lighting columns in the proposed

position of the access, the location should be altered to avoid the obstacle if possible. If this is not feasible, then the applicant will have to pay for the cost of the relocation of the street furniture.

- If there is a tree within the verge outside the property, then any new access must be located so that it does not disturb the roots. This is essentially the area covered by the tree canopy. Highway trees will not normally be removed to facilitate a dropped kerb.
- If an existing access to a property becomes redundant due to the installation of a new access in an alternative location, the pavement will need to be raised back to the original level as part of the works.

Once you have considered the information above, and wish to apply for the licence, please complete the application form and return it to us via e-mail or post (addresses shown on the application form).

All permits required for work affecting the highway i.e. Temporary Traffic Lights, Road Closure Order/Notice, must be applied for, and the permits granted, before any work is commenced. Your contractor may be able to advise whether or not these are necessary.

- If a Road Closure Order/Notice is necessary to safely carry out the works, this will require a separate application and approval. An application form can be obtained by telephoning 01286 679769 or by visiting <https://www.gwynedd.llyw.cymru/en/Businesses/Licences-and-permits/Roads-and-highways-licences/Temporary-Road-Closure-Applications.aspx>
- The provision of any Temporary Traffic Lights which may be necessary will require separate approval. An application form can be obtained by telephoning 01286 679769 or by e-mailing gwaithstryd@gwynedd.llyw.cymru

Safety Considerations

Any application may be refused or modified on the grounds of safety. We will not approve an application if we consider that the vehicle movements may be hazardous. When deciding whether to apply for a Section 184 licence, these points need to be considered.

- You need adequate visibility to be able to see other vehicles and pedestrians using the highway when you enter and exit your drive.
- Proximity to a junction
- Proximity to pedestrian crossing
- Proximity to traffic calming/traffic islands that would make turning difficult
- Proximity to bus stops

This list is not exhaustive and each application will be considered on its own merits.

Planning Permission and Consent

Applicants (homeowners), intending to construct a vehicle crossing must contact their Local Planning Authority, as planning permission may be required. Where required planning permission must be obtained prior to submitting this application.

The formation or alteration of vehicular access on to Classified Roads (i.e. Trunk, Class 1, 2 and 3 Roads) will require planning permission from the Local Planning Authority. Works on Unclassified Roads will not require planning consent however will be subject to conditions proposed by the Highway Authority.

If applicable, a copy of the planning approval must be submitted with this application form.

Following Your Application

Once your application has been received a site inspection will be undertaken to see whether it can be approved or not. Our inspectors may contact you or the appointed contractor if they require any further information.

If your application is successful you will receive the licence approximately 15 working days following the submission and will be valid for three years. If the works are not implemented within that period, the permission will lapse and you will have to re-apply. If your application is not successful, you will receive reasons in writing why it has been refused. You may appeal to a magistrates' court against the refusal or conditions if you wish to do so.

- Once you have appointed the contractor, agree with them when you would like the work to commence and give notice of the intended starting date to the Street Works unit– this is done by completing the 'Part N' notification form enclosed. Please note that the form must be returned as proposed on the works category table stated on the 'Part N' form. If the work does not start on the agreed dates the applicant must forward a new 'Part N' notice form.
- The Licensee is encouraged to ensure that the works are carried out to the timescale specified on the 'Part N' form. Failure to do so could result in charges being applied by the Council under Section 74 of NRSWA. The current maximum charge is £2,500 per day should the works over run.
- Once the works have been completed, you will need to submit the PART R1 form within 10 working days. The future maintenance of the crossing will be the responsibility of the Authority. However if within the first two years following the completion of the works remedial work needs to be undertaken due to poor workmanship or because the works have not followed the agreed specification the contractor/licensee will be notified of required works/action and will be liable for any costs associated with such.
- Failure to send any of the above mentioned forms could result in the issue of a Fixed Penalty Notice, in accordance with the current NRSWA Regulations, or possible prosecution.

Statutory Undertakers

- The applicant will be responsible for ascertaining the location of any apparatus prior to carrying out excavation on site. Any information provided by the Highway Authority is given for general guidance only on the understanding that it is based on the best available information and the applicant should not rely solely upon such information where excavation or other works are to be made in the vicinity of apparatus in the Street.
- Should the statutory undertakers object to the location of works then the applicant must ensure compliance with any conditions set by the Statutory Undertakers under the Highways Act 1980 to prevent damage or ensuring access to apparatus of statutory undertakers.

STATUTORY UNDERTAKERS CONTACT NUMBERS

Dwr Cymru	0800 052 0130
SP Energy Network	0800 027 0072
BT	0800 800 150
Wales & West (Gas)	0800 052 2526

Reinstatement

- Once the works are completed to a satisfactory standard the 2 year Maintenance Period may begin. During this time you will be responsible for any defects in the works.
- The Licensee must indemnify the Council against all and any claims made by a third party in connection with any aspects of the works. This liability extends to the end of the guarantee period for the reinstatement.
- Licensees are encouraged to carry out a permanent reinstatement of the highway immediately on completion of the works. Care must be taken to follow the requirements of the NRSWA Code of Practice, Specification for The Reinstatement of Highways particularly those relating to layer thicknesses and compaction.
- The access must be constructed to the correct specification, vehicular crossing construction, unless otherwise stated on your licence.
- If highway storm drainage systems laid under the vehicular crossing are to be exposed, concrete protection 150mm deep is to be placed around and above the pipe construction.
- It is an offence under the Highways Act 1980 to allow water to discharge on the highway. As such any water must be contained and disposed of within the property, such as through a soak away.
- Where an existing footway is being altered, the full width of the footway must be reconstructed to give an even cross fall from the back edging to the front of the new kerbs. There must also be an edging kerb placed at the rear of the reconstructed footway.

All the conditions are imposed

- In the interests of safety
- To minimise the inconvenience to persons using the street, having particular regard to people with a disability; and
- To protect the structure of the street and the integrity of apparatus within it.

Defect Inspection Fees

Following reinstatement of the works, if the Council identifies any defect the Licensee is required to pay a fee to cover inspections the Council carry out to ensure remedial works are satisfactorily completed.

Investigatory Works

Where a complaint from a member of the public requires a visit to the site and is found to result from a defect in a Licensee's works, the Licensee is required to pay a fee, additional to any defect inspection fee.

Where the Council chooses to core a reinstatement, the licence holder is required to pay the cost of

the core, only if the core identifies an inadequate reinstatement. This is additional to the defect inspection fee.

Emergency Work

If the Licensee is unable to respond to the need to carry out emergency work to make their site safe, the Council has the right to carry out this work and recharge the costs incurred.

Remedial Works

If the Licensee fails to carry out remedial works within the period stated on the notice, the Council has the right to carry out further chargeable defect inspections and if necessary undertake the remedial work and recharge the costs involved. This does not remove the Licensee's responsibility for the reinstatement guarantee.

**ADEILADU MYNEDIAD CERBYDAU
AR GYFER TROEDFFYRDD AG YMYLON
DEUNYDDIAU WEDI EU CYMERADWYO**

TROEDFFORDD – MYNEDIAD I GERBYDAU

Disgrifiad	Defnydd	Cerbydau Ysgafn	Cerbydau Trwm
Cwrs Treulio	Cwrs treulio asffalt poeth wedi'i rowlio	30mm 30mm	40mm 40mm
Cwrs Sylfaen	Cwrs treulio asffalt poeth wedi'i rowlio	50mm 50mm	60mm 60mm
Sylfaen Ffyrdd	Cwrs treulio asffalt poeth wedi'i rowlio	N/A	150mm 150mm
Is-Sylfaen	Is-sylfaen gronynnol math 1	300mm	300mm

TROEDFFORDD MODIWLAIDD

Disgrifiad	Defnydd	Cerbydau Ysgafn	Cerbydau Trwm
Cwrs Treulio	Modiwl		I'w gytuno gyda Awdurdod Priffyrdd
Sylfaen	Tywod neu mortar		
Is- Sylfaen	Is-sylfaen gronynnol	300mm	

TROEDFFORDD ANHYBLYG

Disgrifiad	Defnydd	Cerbydau Ysgafn	Cerbydau Trwm
Cwrs Treulio	Concrid ansawdd palmant	100mm	I'w gytuno gyda Awdurdod Priffyrdd
Sylfaen	Is-sylfaen gronynnol	300mm	

CWRS TREULIO ASFFALT POETH WEDI'I ROWLIO

1. CWRS TREULIO ASFFALT POETH WEDI'I ROWLIO

Cwrs treulio asffalt poeth wedi'i rowlio at BS594: Rhan 1: 1992
Pob cyfeiriad at deunydd macadam i cydfynd a BS4987:Part1: 1993

2. CWRS TREULIO

Rhaid i'r cwrs treulio HRA safonol cydymffurfio a 15/10 HRAWC Recipe Type F, 100 neu 50 pen, neu Tabl 6, Colofn 6/2

3. CWRS SYLFAEN

Rhaid i'r cwrs sylfaen HRA safonol cydymffurfio a 50/20 HRABC Type , 100 neu 50 pen, i Tabl2, Colofn 2/3. Gellir newid y safon yma gyda Macadam cwrs sylfaen dwys maint 20mm, 200 neu 100 pen i Cymal 6.5

MACADAM DWYS

1. OPSIYNNAU DEUNYDD MACADAM DWYS

Pob cyfeiriadau at manyleb deunydd macadam i BS4976: Part 1: 1993
Pob cyfeiriadau at deunydd HRA i BS594:Part 1: 1992.

2. DEUNYDD CWRS TREULIO

Rhaid i'r deunydd cwrs treulio dwys safonol fod yn cwrs treulio dwys 6mm, 200 neu 100 pen, i cymal 7.5. Gellir newid y deunydd safonol gyda deunydd arall i cydfynd a'r gwyneb macadam presenol.

3. DEUNYDD CWRS TREULIO – CROESFANNAU CERBYDAU TRWM

Rhaid i'r deunydd cwrs treulio dwys safonol fod yn 14mm, 200 neu 100 pen, i cymal 7.3. Gellir newid y deunydd safonol gyda deunydd arall i'w gytuno gan y Cyfarwyddwr.

4. DEUNYDD CWRS SYLFAEN

Rhaid i'r deunydd cwrs Sylfaen dwys safonol fod yn cwrs sylfaen dwys 20mm, 200 neu 100 pen, i cymal 6.5. Gellir newid y deunydd safonol gyda 50/20 HRABC Type F, 100 neu 50 pen, i Tabl 2, Colofn 2/3.

**CONSTRUCTION OF VEHICLE ACCESS
CROSSINGS OVER FOOTWAYS AND VERGES**

APPROVED MATERIALS

FLEXIBLE FOOTWAYS – VEHICLE ACCESS

Details			Light Vehicles	Heavy Vehicles	Special Requirements
Ref	Description	Material	Thickness (mm)	Thickness (mm)	
1.	Wearing Course	Hot Rolled Asphalt	30	40	☒
		Dense Bitumen macadam	30	40	
2.	Basecourse	Hot Rolled Asphalt	50	60	☒
		Dense Bitumen macadam	50	60	
3.	Roadbase	Hot Rolled Asphalt	N/A	150	☒
		Dense Bitumen macadam		150	
4.	Sub-base	Granular Sub-base Type 1	300	300	☒

MODULAR FOOTWAYS

Ref	Description	Material	Thickness (mm)		
1.	Wearing Course	Module		Construction details to be agreed with the Director	☒
2.	Bed	Sand or Mortar			
3.	Sub-base	Granular Sub-base Type 1	300		

RIGID FOOTWAYS

Ref	Description	Material	Thickness (mm)		
1.	Wearing Course	Pavement Quality Concrete	Min 100	C40 Concrete construction details to be agreed with the Director	☒
2.	Bed	Granular Sub-base Type 1	300		

HOT ROLLED ASPHALT (HRA)

1. HOT ROLLED ASPHALT (HRA) Material Options

All HRA material references are to BS594: Part 1: 1992.

All macadam material specification references are to BS4987: Part 1: 1993

2. WEARING COURSE MATERIALS.

The standard HRA wearing course shall be 15/10 HRAWC Recipe Type F, 100 or 50 pen, or Table 6, Column 6/2.

3. BASECOURSE MATERIALS.

The standard HRA basecourse material shall be 50/20 HRABC Type F, 100 or 50 pen, to Table 2, Column 2/3. This standard may be replaced by 20mm Dense Basecourse Macadam, 200 or 100 pen, to Clause 6.5

DENSE MACADAM

1. DENSE MACADAM Material Options

All macadam material specification references are to BS4987: Part 1: 1993

All HRA material references are to BS594: Part 1: 1992.

2. WEARING COURSE MATERIALS

The standard dense macadam wearing course material shall be 6mm Dense Wearingcourse, 200 or 100 pen, to Clause 7.5. The standard material may be replaced by other alternative materials to match existing coated macadam surface.

3. WEARING COURSE MATERIALS – HEAVY VEHICLE CROSSING

The standard dense Macadam wearing course material shall be 14mm, 200 or 100 pen to Clause 7.3. The standard material may be replaced by other alternative materials as agreed by the Director

4. BASECOURSE MATERIALS.

The standard dense macadam basecourse material shall be 20mm Dense Basecourse, 200 or 100 pen, to Clause 6.5. This standard may be replaced by 50/20 HRABC Type F, 100 or 50 pen, to Table 2, Column 2/3.

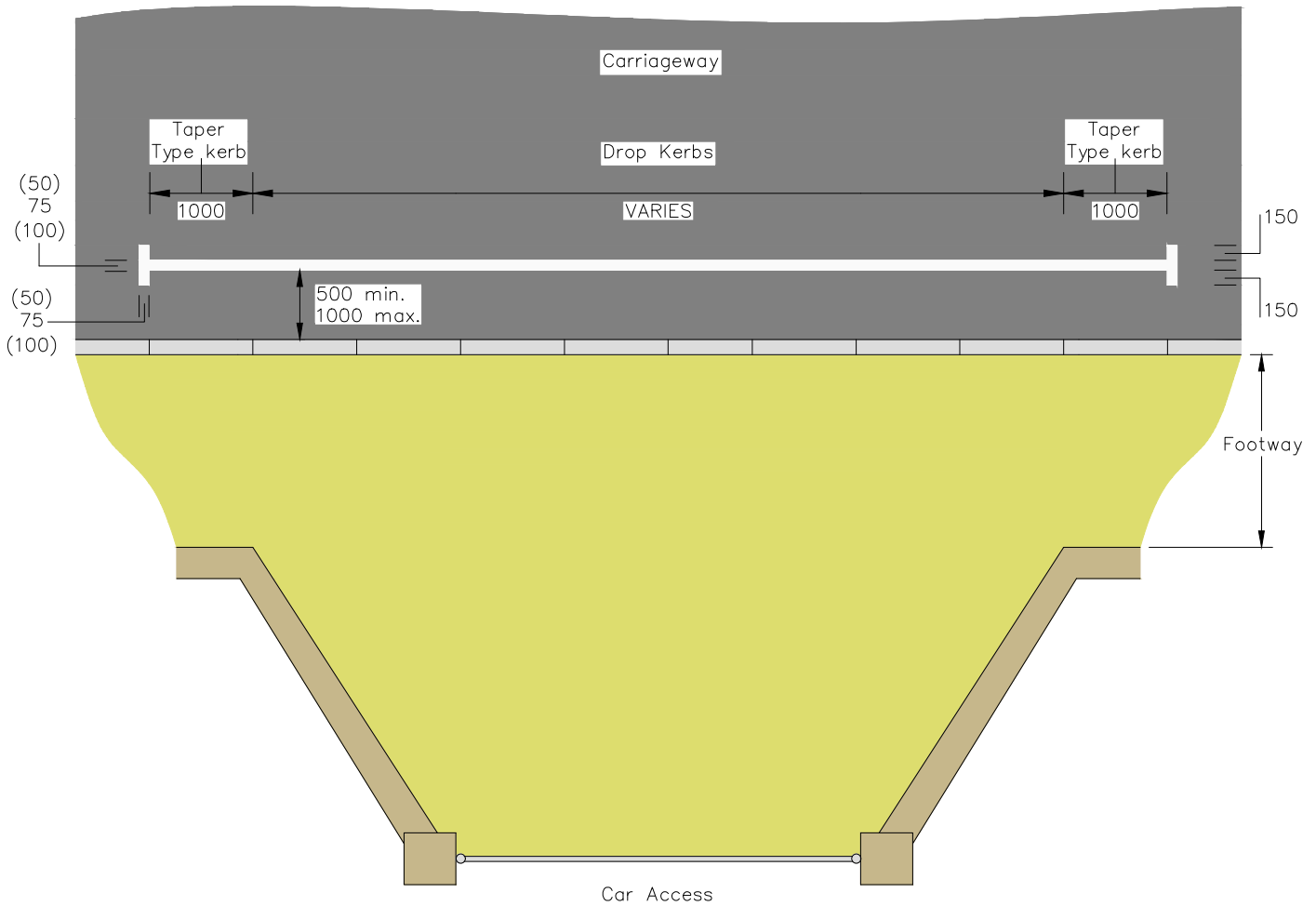

ACCESS PROTECTION MARKING DETAIL
(Diagram No 1026.1)

Note:

1. All dimensions in are in millimetres.
2. The drawing indicates provisionally the road marking requirements with the exact position of all markings to be agreed on site by the Highway Authority.
3. All road markings to be laid in white (or otherwise) stated reflectorised thermoplastic screed material with surface application of solid glass beads to clause SHW 1212.
4. All Traffic Signs and Road Markings to conform to 'The Traffic Signs and Regulations and General Directions 2016'.
5. The marking to diagram 1026.1 may be laid on part of the carriageway which should be kept clear of parked vehicles either outside an entrance to off-street premises, or where the kerb is dropped to provide a convenient crossing place for pedestrians.
6. It should normally be laid **75mm** wide for speed limits up to 40mph and **100mm** when the limit is higher. The **50mm** size may be used in environmentally sensitive areas.
7. All proposed Road markings to tie-in with existing markings.

CYNLLUN / SCHEME : STANDARD DETAIL DRAWING	DARLUNWYD GAN : DRAWN BY : PT	
	DYDDIAD DARLUNWYD : DATE DRAWN : Mar.2019	
TEITL LLUNIAD / DRAWING TITLE : ACCESS PROTECTION MARKING DETAIL	GRADDFEYDD : SCALES : Not to Scale	
	Rhif Lluniad Drawing No. ***/**/***	

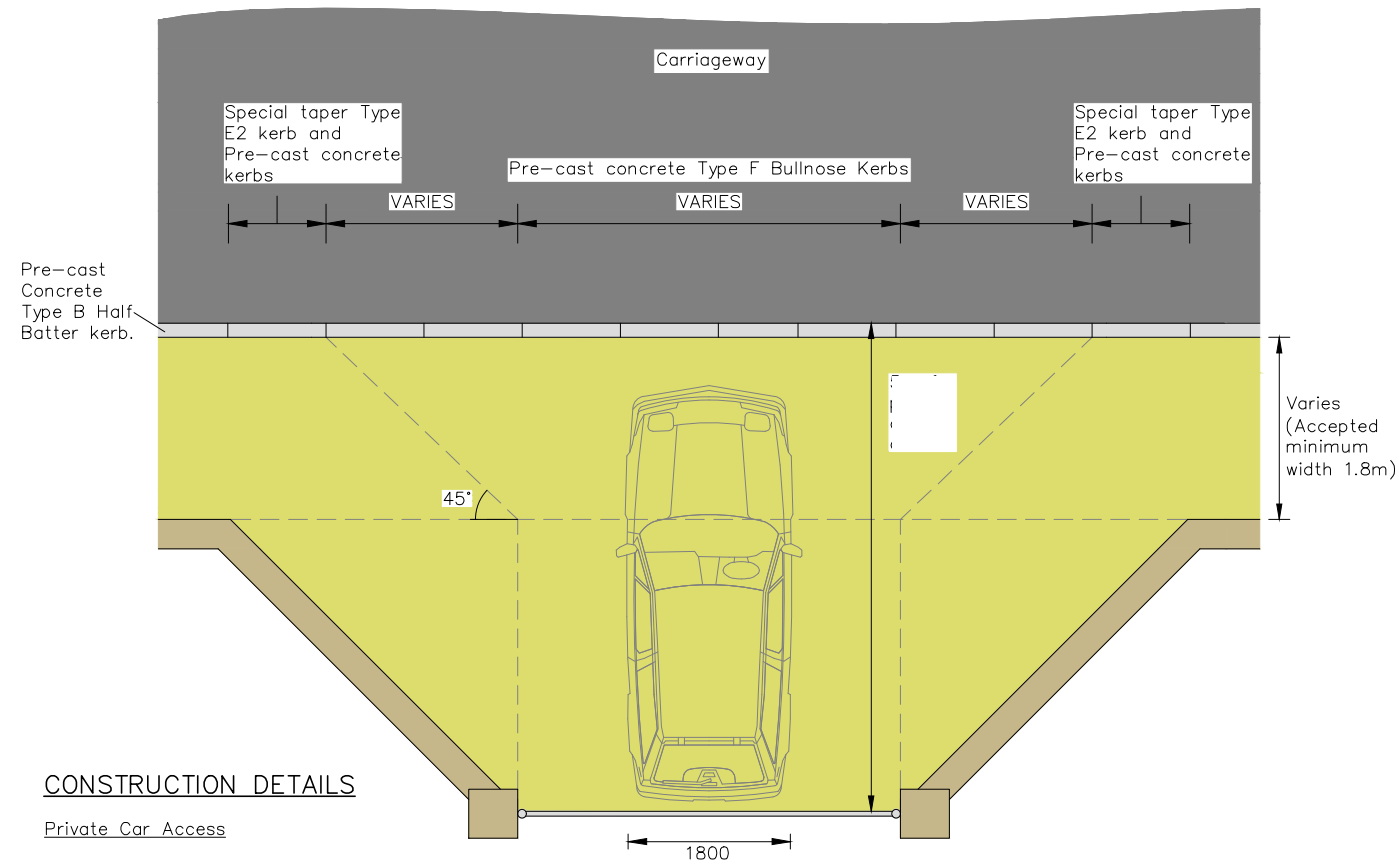

CONSTRUCTION DETAILS

Private Car Access

Wearing Course	20mm
Base Course	40mm
Sub Base	150mm

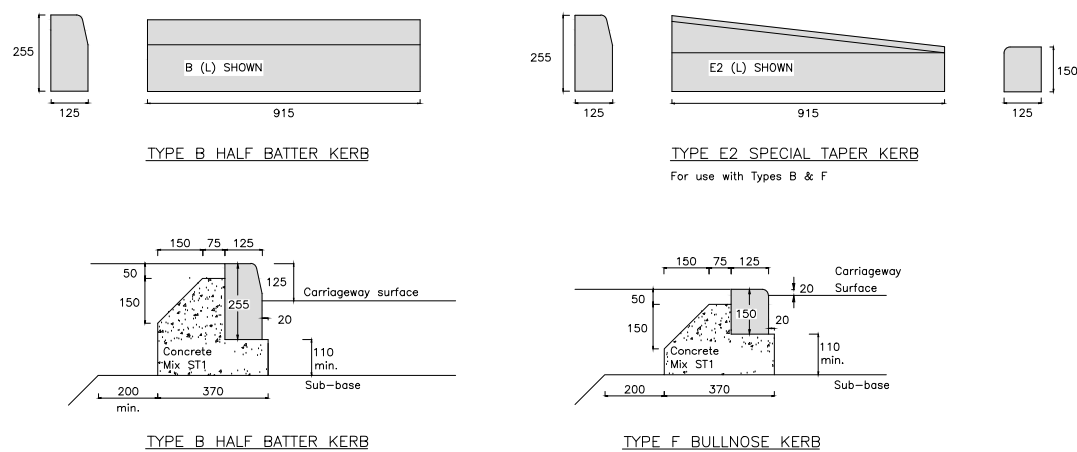

CONCRETE KERB DETAILS

Note:

1. All dimensions in are in millimetres.
2. All kerbs to be to BS 7263:part1.
3. Localised placing of sub-base to support the kerb race will not be permitted.
4. Special kerbs to be bedded on a foundation which matches and merges in with the adjacent standard kerb foundation.
5. Bedding and backing to kerbs is to be a semi-dry concrete mix ST1, placed in formwork which is not struck until at least 24 hours after placing concrete.
6. The Contractor will take all steps, such as weepholes in the foundation, necessary to prevent ponding on the lower carriageway layers, before completion of carriageway construction.
7. The measurement of roadbase, sub-base, drainage and/or kerbing shall not be affected, either in quantity or itemisation, by any eventualities of permitted methods of construction.
8. All materials and construction to conform to M.C.H.W. Specification for Highway Works, and amendments as applicable.

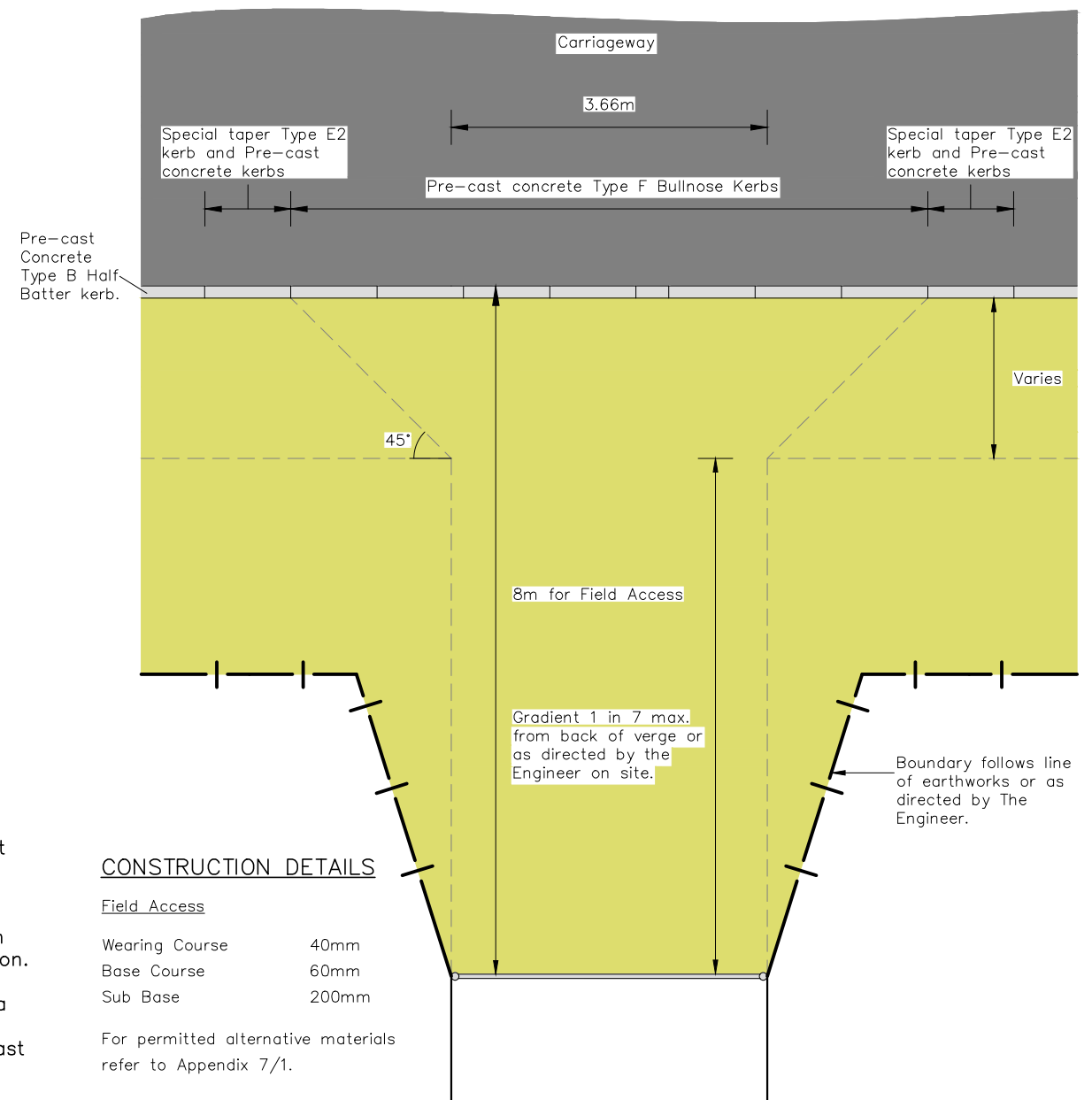

CONSTRUCTION DETAILS

Field Access

Wearing Course	40mm
Base Course	60mm
Sub Base	200mm

For permitted alternative materials refer to Appendix 7/1.

Access extended in 200 sub base as necessary to meet existing ground level.

FIELD ACCESS DETAIL

CYNLLUN / SCHEME :

STANDARD DETAIL DRAWING

TEITL LLUNIAD / DRAWING TITLE :

TYPICAL ACCESS DETAILS

DARLUNWYD GAN : DRAWN BY :	PT	DYDDIAD DARLUNWYD : DATE DRAWN :	Mar.2019
GWIRIWDYD GAN : CHECKED BY :	GH	DYDDIAD GWIRIWDYD : DATE CHECKED :	Mar.2019
Taflen Sheet	o of	GRADDFEYDD : SCALES :	Not to Scale
Rhif Lluniad Drawing No.	***/***/***		CYWI REV

